



Product introduction



“

F22

Introduction

Thank you for purchasing the F22 model. Our T-ONE model has invested 2 years of energy and time for this model. After repeated verification and modification, we hope to give customers a perfect flight experience. Please note that the photos in this instruction manual show some views of the prototype. The model's release may have undergone some modifications and upgrades. This manual describes the assembly of the "PRO" model. Before you start building and setting up your aircraft, make sure you read and understand the instruction manual. If you have any question,

Please don't hesitate to contact us.



”



Specifications F22



Length: 2.7m (106.3")

Wing Span: 1.948m (76.7")

Weight: 23–26KG (50.7–57.32lbs) Dry weight with turbine, servos, retracts, pipe, tank and full UAT.

Center of Gravity: 275mm – 290mm from leading edge of wing root.

Recommended Aileron Throw: 45mm

Recommended Elevator Throw: 70mm

Recommended Rudder Throw: 55mm

Recommended Flap Throw: Half flaps = 40mm, Full flaps = 70mm



F22 ARF PRO Contents



- 1.Right wing including Doors .include flap + aileron.
- 2.Left wing including Doors .include flap + aileron.
- 3.Front fuselage.
- 4.The middle of the fuselage includes: fuselage + landing gear + Doors.
- 5.tail section: contains the installed vector nozzle.
- 6.Flat tail: right + left.
- 7.Vertical tail: right + left.
- 8.Cockpit.
- 9.Canopy.
- 10.engine access hatch.
- 11.Fuel tank * 3
- 12.assembly parts bag.



Assembly details

Nose Gear Steering:
This is the nose gear assembly and included hardware.



Mount the nose steering servo in the configuration shown.

Note: Always use blue thread- locker on all metal-to-metal connections.





Assembly details

Flap servo mounting
Control linkages : 50mm



Aileron servo installation
Control linkages : 60mm
T-shaped aluminum angle fixed servo

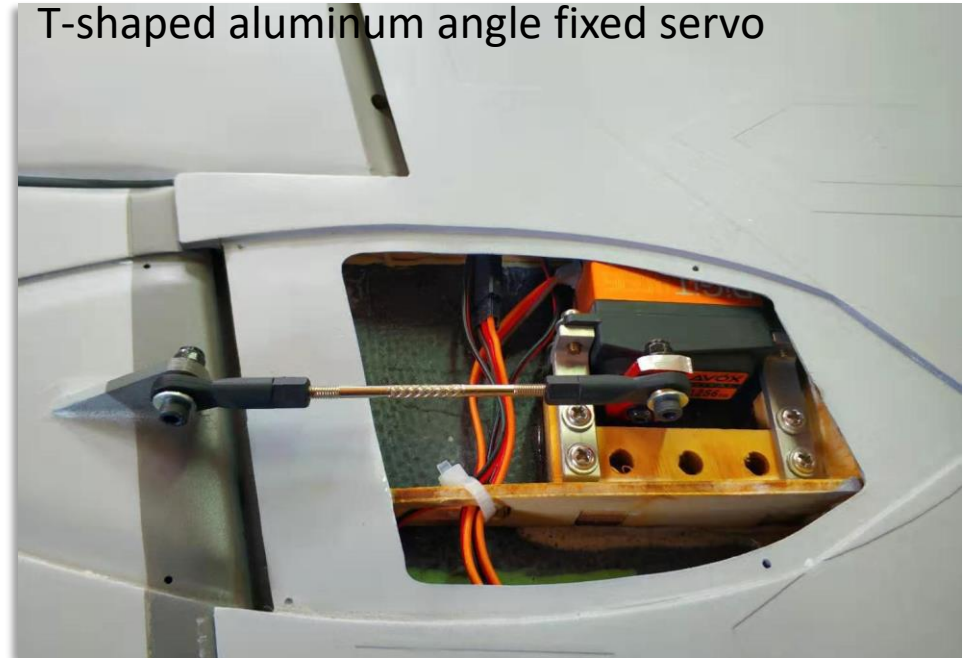



Assembly details

Lifting servo installation. Rocker hole distance : 15mm

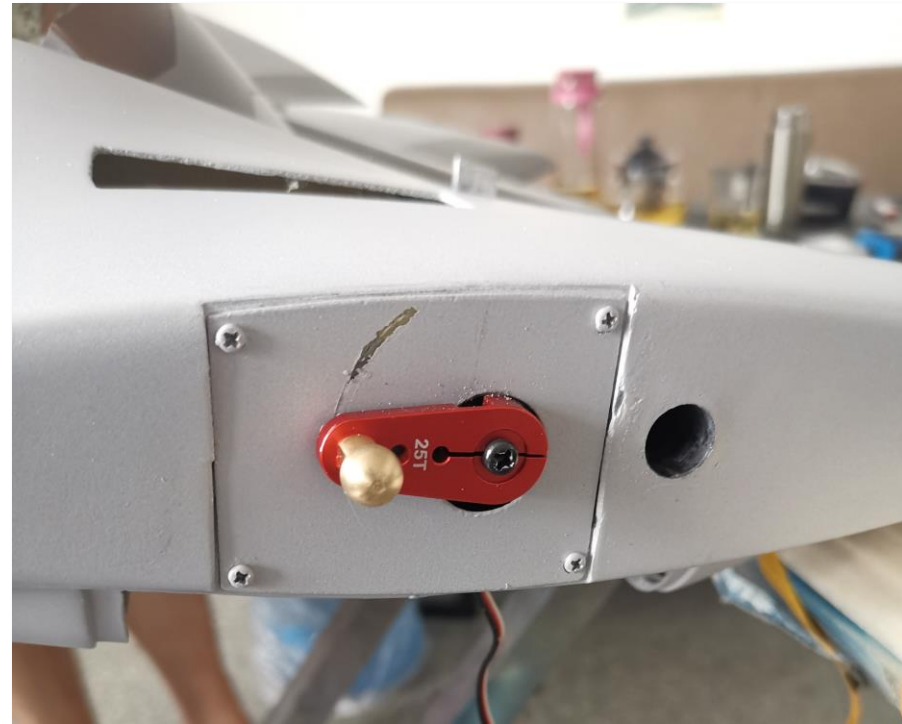



Assembly details

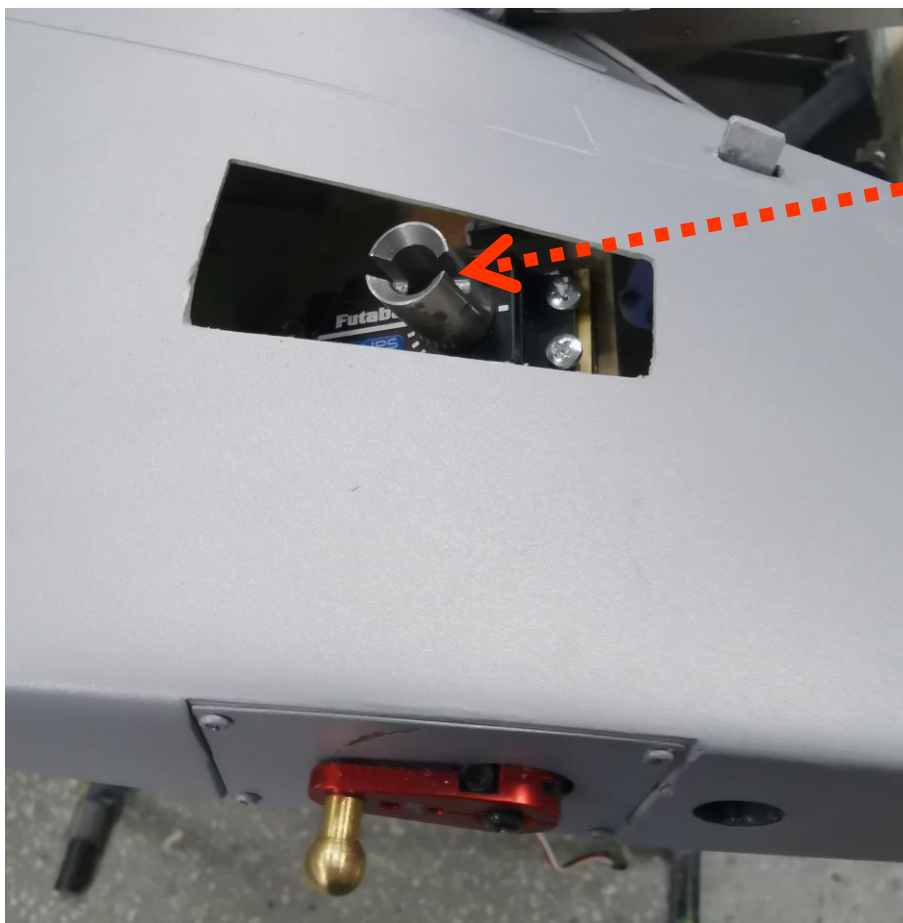

Rudder Servo Installation.

Note the matching angle between the slot and the rudder joint, to ensure that the rudder center point is correct.

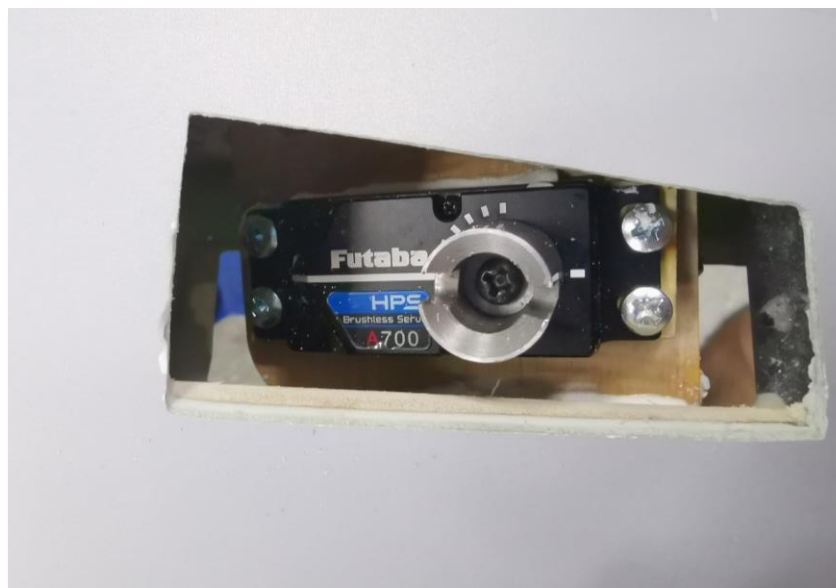



Assembly details



Leading edge flap servo mounting.

L-shaped aluminum angle fixed servo



Assembly details



Vector spout servo installation.

Note: Always use blue thread- locker on all metal-to-metal connections.





Assembly details



Single-engine installation diagram.



Assembly details

Dual-engine installation.

First fix the "connection piece" on the engine

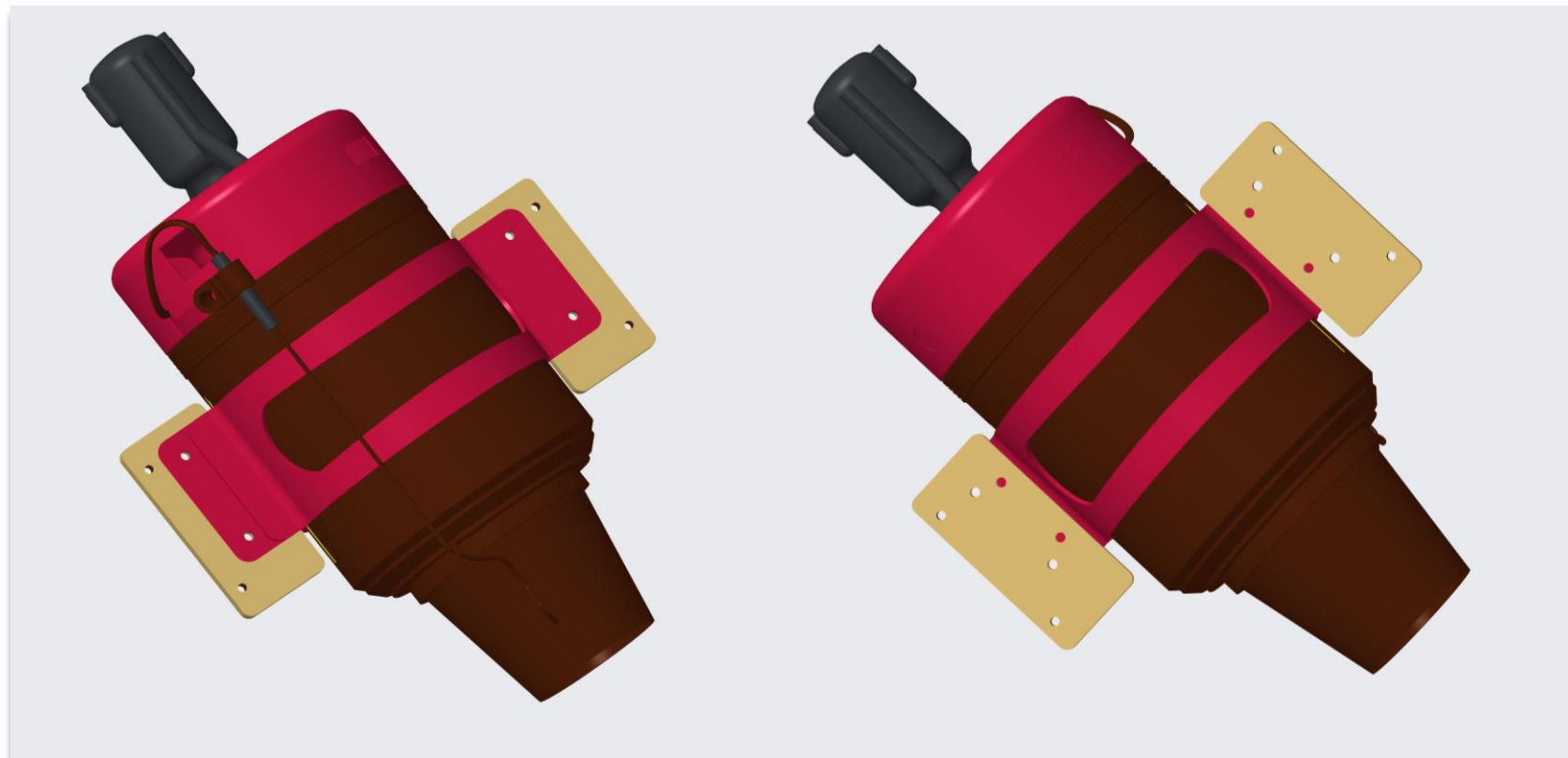



Assembly details

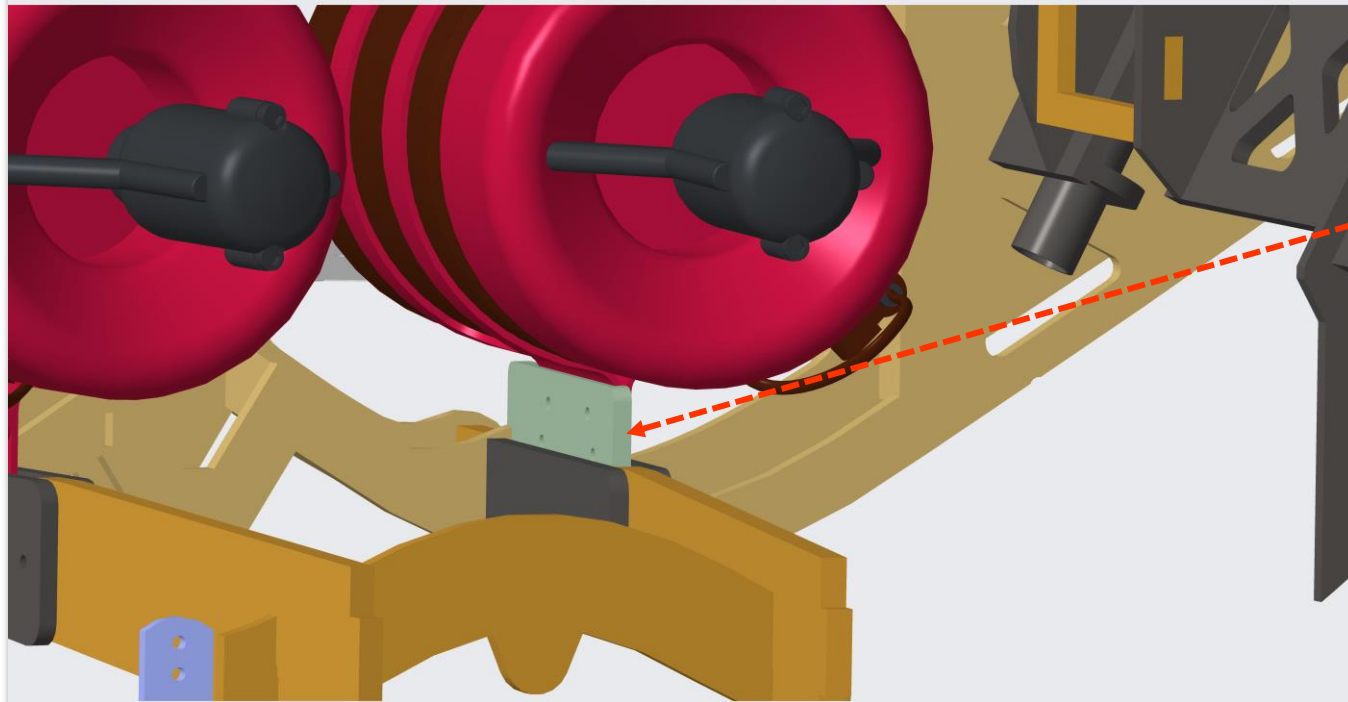

Fuel inlet facing up

Insert the other engine “connecting piece” into the card slot as the picture shows

Please note: different sizes of “connection piece” are customized according to engine size



Assembly details

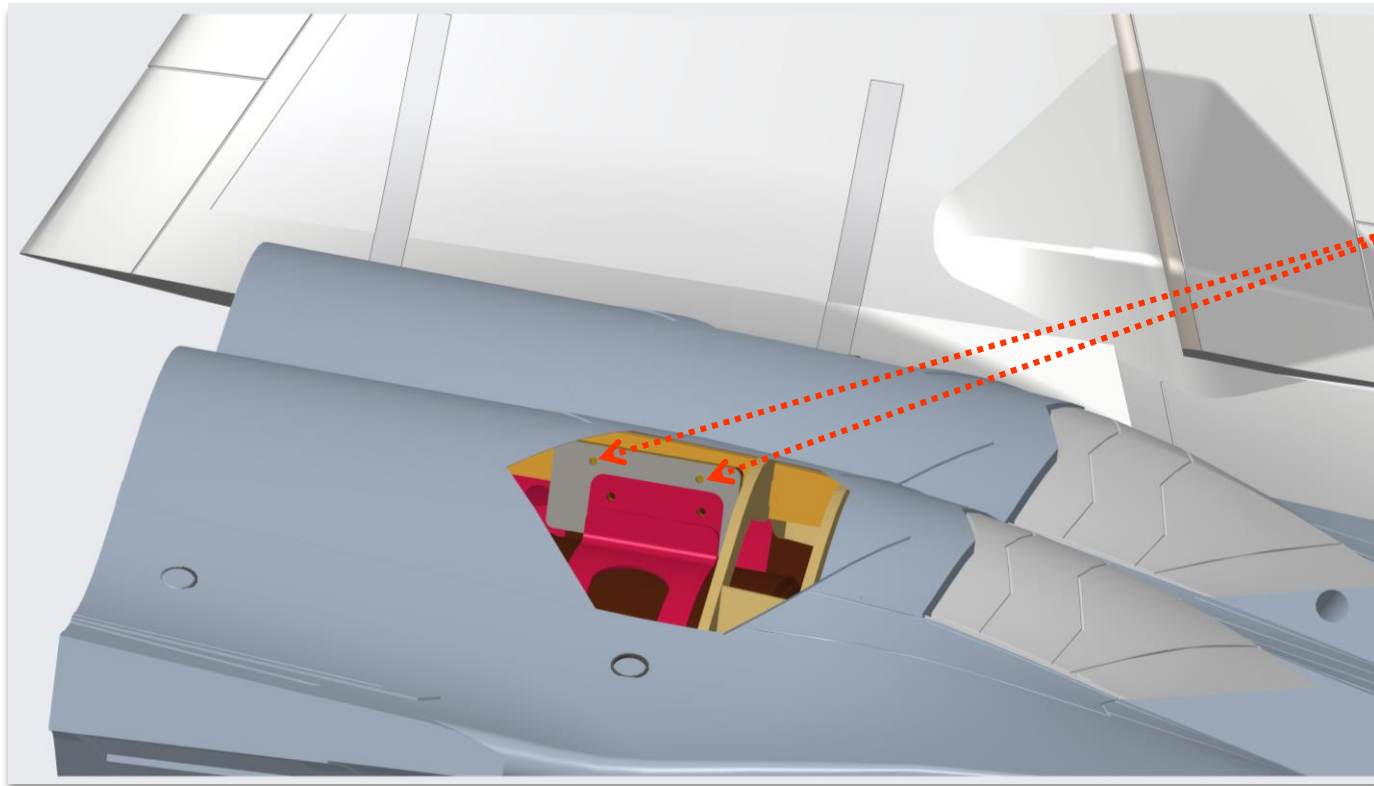

The "connection piece" on the engine is fixed to the beam with self-tapping screws



Assembly details

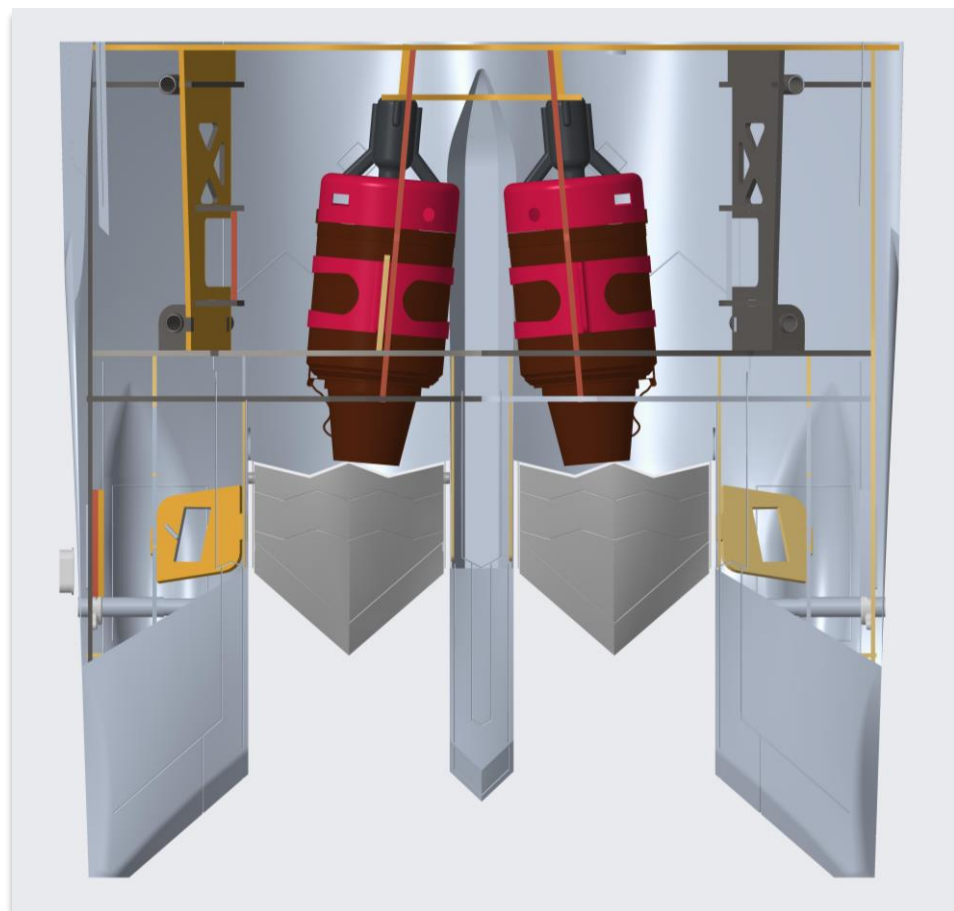

The engine thrust line passes through the model airplane CG to ensure that when one engine goes out, the other engine can make the model airplane land safely.

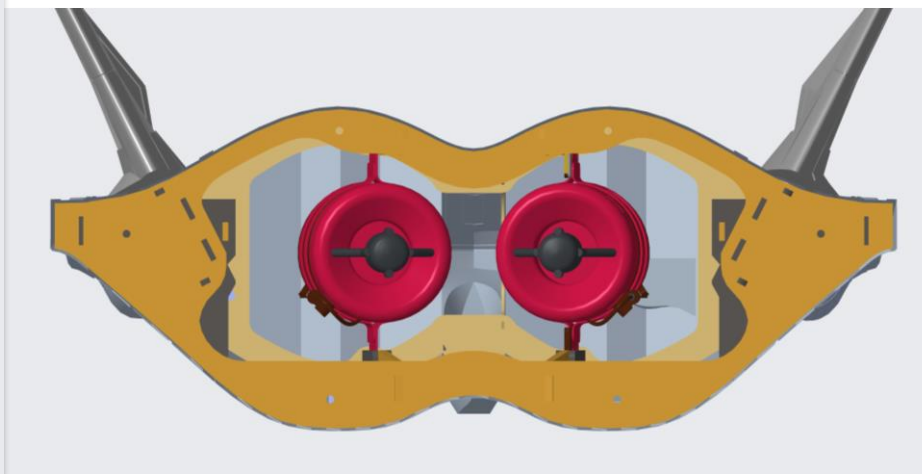



Assembly details

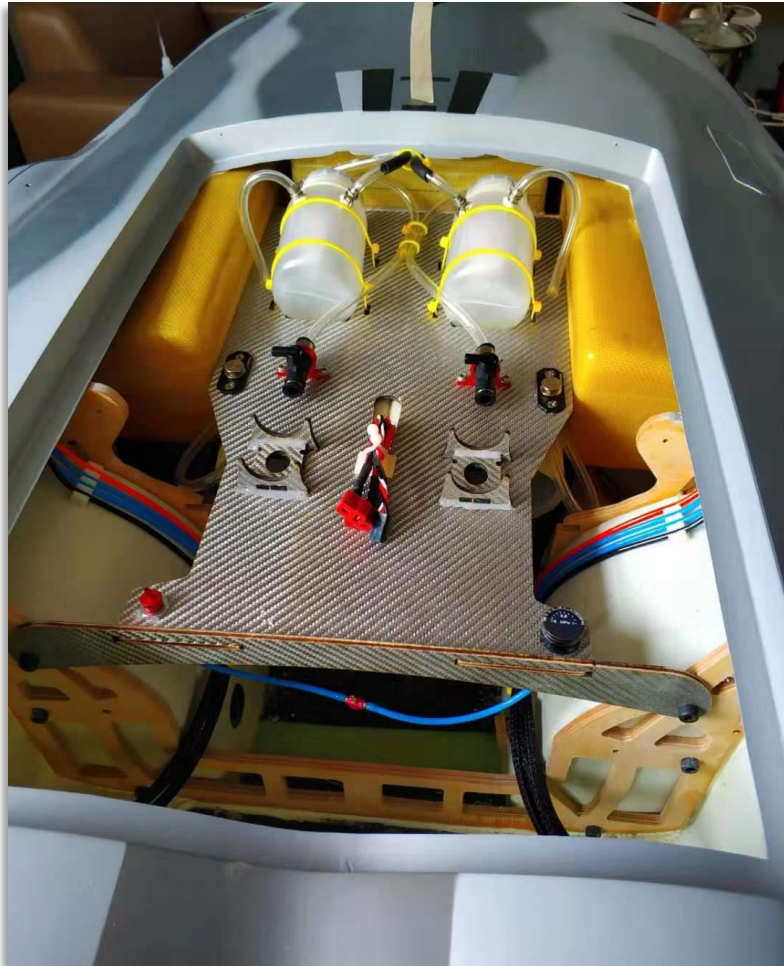

Dual-engine, UAT installation location recommended



Assembly details

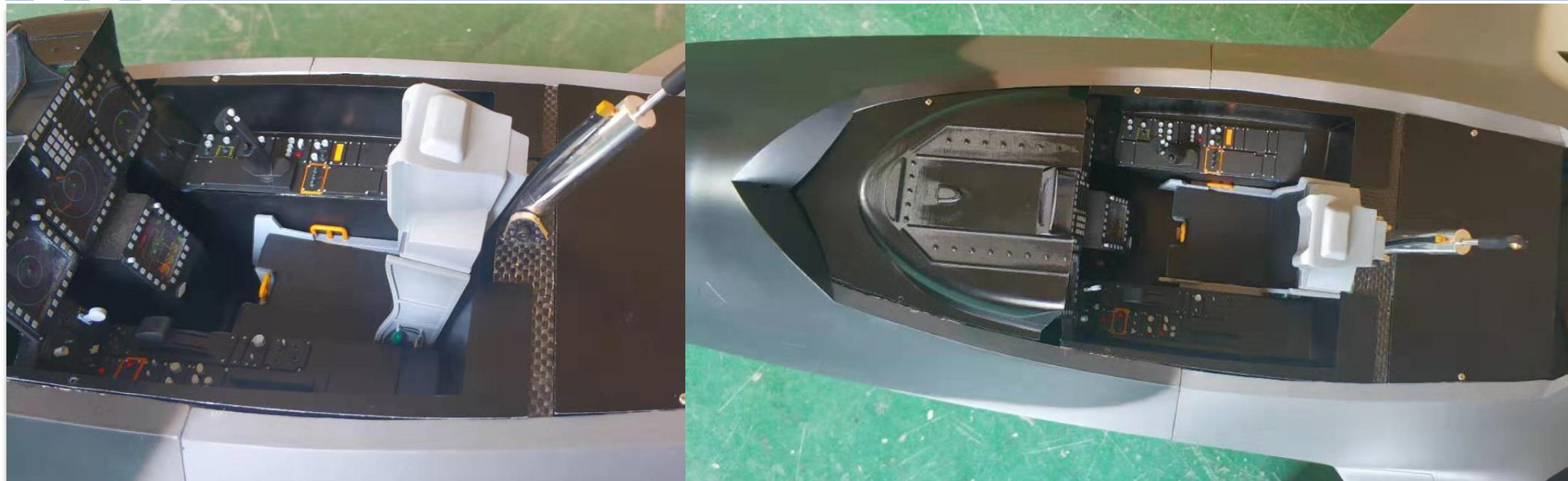

Cockpit installation

Document:
Version 1.0 – February 2020 – Initial
composition and release.